

## INTRODUCTION

Waveform or function generators capable of producing AM/FM modulated sine wave outputs find a wide range of applications in electrical measurement and laboratory instrumentation. This application note describes the design, construction and performance of such a complete function generator system suitable for laboratory usage or hobbyist applications. The entire function generator is comprised of a single XR-2206 monolithic IC and a limited number of passive circuit components. It provides the engineer, student, or hobbyist with a highly versatile laboratory instrument for waveform generation, at a very small fraction of the cost of conventional function generators available today.

## GENERAL DESCRIPTION

The basic circuit configuration and the external components necessary for the high-quality function generator system is shown in *Figure 1*. The circuit shown is designed to operate with either a 12V single power supply, or with 16V split supplies. For most applications, split-supply operation is preferred since it results in an output dc level which is nearly at ground potential.

The circuit configuration of *Figure 1* provides three basic waveforms: sine, triangle and square wave. There are four overlapping frequency ranges which give an overall frequency range of 1Hz to 100KHz. In each range, the frequency may be varied over a 100:1 tuning range.

The sine or triangle output can be varied from 0 to over 6V (peak to peak) from a 600Ω source at the output terminal.

A squarewave output is available at the sync output terminal for oscilloscope synchronizing or driving logic circuits.

## TYPICAL PERFORMANCE CHARACTERISTICS

The performance characteristics listed are not guaranteed or warranted by EXAR Corporation.

However, they represent the typical performance characteristics measured by EXAR's application engineers during the laboratory evaluation of the function generator system shown in *Figure 1*. The typical performance specifications listed below apply only when all of the recommended assembly instructions and adjustment procedures are followed:

- (a) **Frequency Ranges:** The function generator system is designed to operate over four overlapping frequency ranges:

1Hz	to	100Hz
10Hz	to	1KHz
100Hz	to	10KHz
1KHz	to	100KHz

The range selection is made by switching in different timing capacitors.

- (b) **Frequency Setting:** At any range setting, frequency can be varied over a 100:1 tuning range with a potentiometer (see R13 of *Figure 1*.)
- (c) **Frequency Accuracy:** Frequency accuracy of the XR-2206 is set by the timing resistor R and the timing capacitor C, and is given as:

$$f = 1/RC$$

The above expression is accurate to within 15% at any range setting. The timing resistor R is the series combination of resistors R4 and R13 of *Figure 1*. The timing capacitor C is any one of the capacitors C3 through C6, shown in the figure.

- (d) **Sine and Triangle Output:** The sine and triangle output amplitudes are variable from 0V to 6Vpp. The amplitude is set by an external potentiometer, R12 of *Figure 1*. At any given amplitude setting, the triangle output amplitude is approximately twice as high as the sinewave output. The internal impedance of the output is 600Ω.

(e) **Sinewave Distortion:** The total harmonic distortion of sinewave is less than 1% from 10Hz to 10KHz and less than 3% over the entire frequency range. The selection of a waveform is made by the triangle/sine selector switch, S2.

(f) **Sync Output:** The sync output provides a 50% duty cycle pulse output with either full swing or upper half swing of the supply voltage depending on the choice of sync output terminals on the printed circuit board (see Figure 1.)

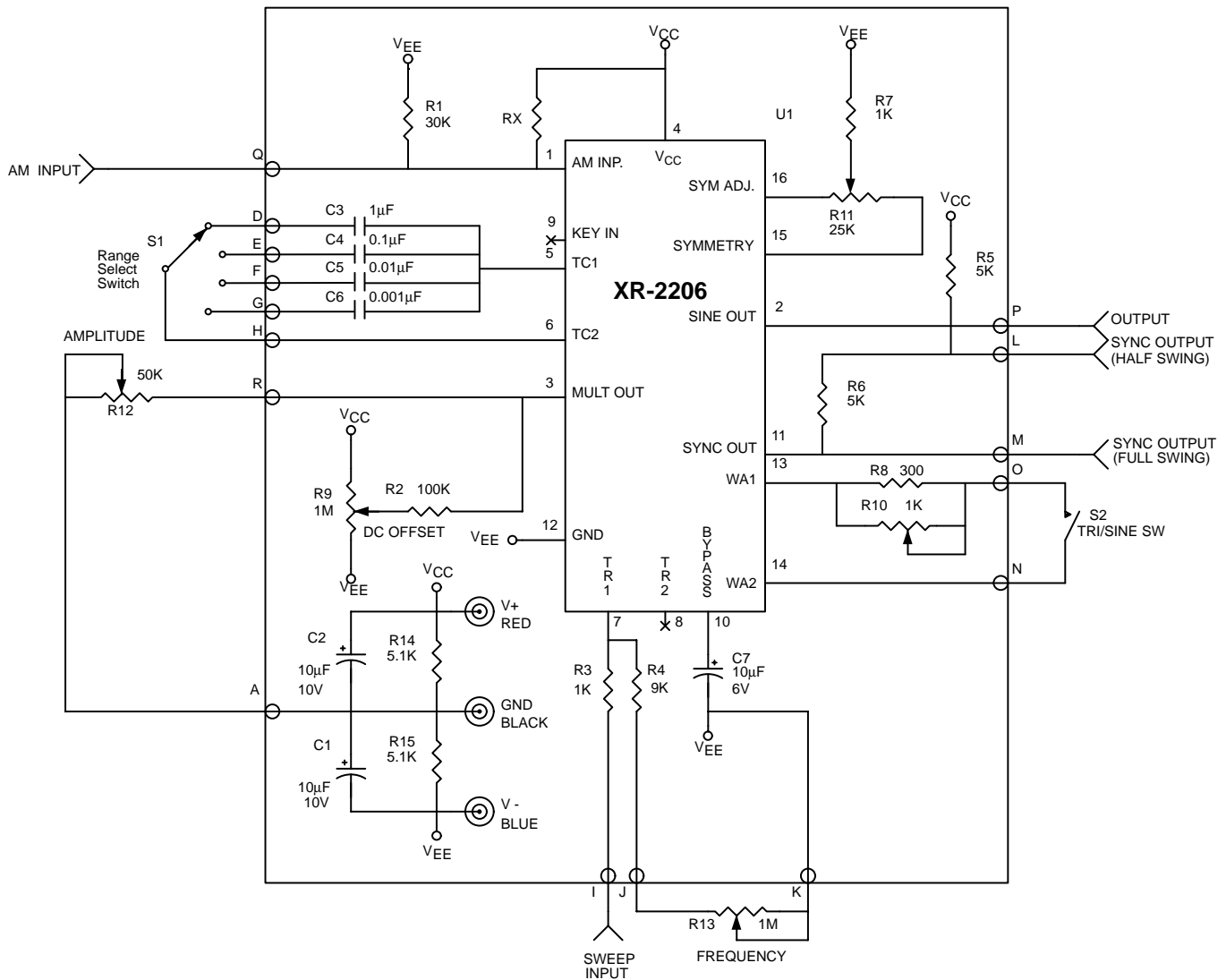

Figure 1. Circuit Connection Diagram for Function Generator  
(See (i) for Single Supply Operation)

- g) **Frequency Modulation (External Sweep):**  
 Frequency can be modulated or swept by applying an external control voltage to sweep terminal (Terminal I of *Figure 1*.) When not used, this terminal should be left open circuited. The open circuit voltage at this terminal is approximately 3V above the negative supply voltage and its impedance is approximately 1000Ω.
- (h) **Amplitude Modulation:** The output amplitude varies linearly with modulation voltage applied to AM input (terminal Q of *Figure 1*.) The output amplitude reaches its minimum as the AM control voltage approaches the half of the total power supply voltage. The phase of the output signal reverses as the amplitude goes through its minimum value. The total dynamic range is approximately 55dB, with AM control voltage range of 4V referenced to the half of the total supply voltage. When not used, AM terminal should be left open-circuited.
- (i) **Power Source: Split Supplies:** +/-6V, or single supply: +12V. Supply Current 15mA (see *Figure 2*). For single supply operation bias resistors, R14 and R15 should be added, the GND point left floating and V-tied to ground.

## EXPLANATION OF CIRCUIT CONTROLS

### Switches

*Range Select Switch, S1:* Selects the frequency range of operation for the function generator. The frequency is inversely proportional to the timing capacitor connected across Pins 5 and 6 of the XR-2206 circuit. Nominal capacitance values and frequency ranges corresponding to switch positions of S1 are as follows:

Position	Nominal Range	Timing Capacitance
1	1Hz to 100Hz	1μF
2	10Hz to 1KHz	0.1μF
3	100Hz to 10KHz	0.01μF
4	1Hz to 100kHz	0.001μF

If additional frequency ranges are needed, they can be added by introducing additional switch positions.

*Triangle/Sine Waveform Switch, S2:* Selects the triangle or sine output waveform.

### Trimmers and Potentiometers

*DC Offset Adjustment, R9:* The potentiometer used for adjusting the dc offset level of the triangle or sine output waveform.

*Sinewave Distortion Adjustment, R10:* Adjusted to minimize the harmonic content of sinewave output.

*Sinewave Symmetry Adjustment, R11:* Adjusted to optimize the symmetry of the sinewave output.

*Amplitude Control, R12:* Sets the amplitude of the triangle or sinewave output.

*Frequency Adjust, R13:* Sets the oscillator frequency for any range setting of S1. Thus, R13 serves as a frequency dial on a conventional waveform generator and varies the frequency of the oscillator over an approximate 100 to 1 range.

### Terminals

- A. Negative Supply -6V
- B. Ground
- C. Positive Supply +6V
- D. Range 1, timing capacitor terminal
- E. Range 2, timing capacitor terminal
- F. Range 3, timing capacitor terminal
- G. Range 4, timing capacitor terminal
- H. Timing capacitor common terminal
- I. Sweep Input
- J. Frequency adjust potentiometer terminal
- K. Frequency adjust potentiometer negative supply terminal
- L. Sync output (1/2 swing)
- M. Sync output (full swing)
- N. Triangle/sine waveform switch terminals
- O. Triangle/sine waveform switch terminals
- P. Triangle or sinewave output
- Q. AM input
- R. Amplitude control terminal

## PARTS LIST

The following is a list of external circuit components necessary to provide the circuit interconnections shown in *Figure 1*.

### Capacitors:

C1, C2, C7	Electrolytic, 10 $\mu$ F, 10V
C3	Mylar, 1 $\mu$ F, nonpolar, 10%
C4	Mylar, 0.1 $\mu$ F, 10%
C5	Mylar, 0.01 $\mu$ F, 10%
C6	Mylar, 1000pF, 10%

### Resistors:

R1	30K $\Omega$ , 1/4 W, 10%
R2	100K $\Omega$ , 1/4 W, 10%
R3, R7	1K $\Omega$ , 1/4 W, 10%
R4	9K $\Omega$ , 1/4 W, 10%
R5, R6	5K $\Omega$ , 1/4 W, 10%
R8	300K $\Omega$ , 1/4 W, 10%
RX	62K $\Omega$ , 1/4 W, 10% (RX can be eliminated for maximum output)

The following two resistors are used in single supply applications:

R14, R15	5.1K $\Omega$ , 1/4 W 10%
----------	---------------------------

### Potentiometers:

R9	Trim, 1M $\Omega$ , 1/4 W
R10	Trim, 1K $\Omega$ , 1/4 W
R11	Trim, 25K $\Omega$ , 1/4 W

The following additional items are recommended to convert the circuit of *Figure 1* to a complete laboratory instrument:

### Potentiometers:

R12	Amplitude control, linear, 50K $\Omega$
R13	Frequency control, audio taper, 1M $\Omega$

### Switches:

S1	Rotary switch, 1-pole, 4 positions
S2	Toggle or slide, SPST

### Power Supply:

Dual supplies 16V or single +12V  
Batteries or power supply unit  
(See *Figure 2 (a)* and *Figure 2 (b)*.)

### Miscellaneous:

Knobs, solder, wires, terminals, etc.

## BOARD LAYOUT

Care should be given to the layout of the board, to prevent noise from the supplies from affecting the XR-2206 performance.

Any simple power supply having reasonable regulation may be used. *Figure 2* gives some recommended power supply configurations.

*Precaution: Keep the lead lengths small for the range selector switch. This will reduce stray capacitance.*

## ADJUSTMENT PROCEDURE

When assembly is completed and you are ready to put the function generator into operation, make sure that the polarity of power supply and the orientation of the IC unit are correct. Then apply the dc power to the unit.

To adjust for minimum distortion, connect the scope probe to the triangle/sine output. Close S2 and adjust the amplitude control to give non-clipping maximum swing. Then adjust R10 and R11 alternately for minimum distortion by observing the sinusoidal waveform. If a distortion meter is available, you may use it as a final check on the setting of sine-shaping trimmers. The minimum distortion obtained in this manner is typically less than 1% from 1Hz to 10KHz and less than 3% over the entire frequency range.

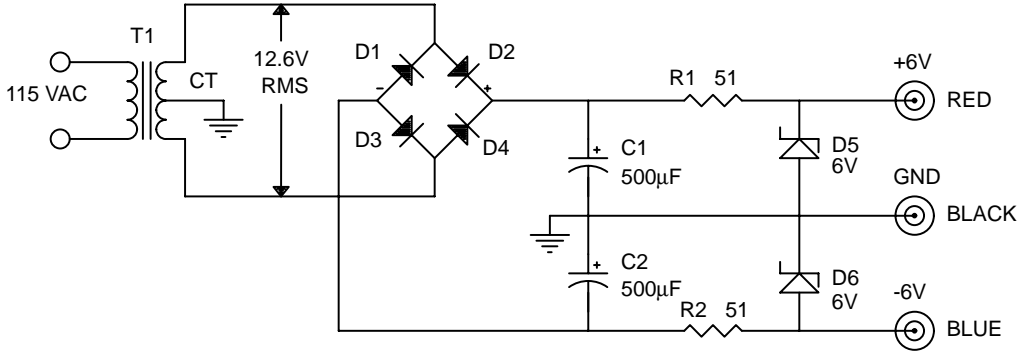

(a) Zener Regulated Supply

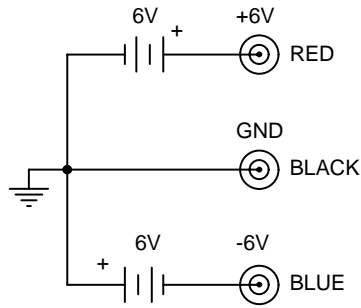

(b) Battery Power Supply

T1: Filament Transformer (Primary 115V Secondary 12.6 VCT 0.5A)

D1 - D4: 1N4001 or Similar

D5, D6: 1N4735 or Similar

R1, R2: 51Ω, 1/2W, 10%

Figure 2. Recommended Power Supply Configurations

**Notes**

**Notes**

## NOTICE

EXAR Corporation reserves the right to make changes to the products contained in this publication in order to improve design, performance or reliability. EXAR Corporation assumes no responsibility for the use of any circuits described herein, conveys no license under any patent or other right, and makes no representation that the circuits are free of patent infringement. Charts and schedules contained here in are only for illustration purposes and may vary depending upon a user's specific application. While the information in this publication has been carefully checked; no responsibility, however, is assumed for inaccuracies.

EXAR Corporation does not recommend the use of any of its products in life support applications where the failure or malfunction of the product can reasonably be expected to cause failure of the life support system or to significantly affect its safety or effectiveness. Products are not authorized for use in such applications unless EXAR Corporation receives, in writing, assurances to its satisfaction that: (a) the risk of injury or damage has been minimized; (b) the user assumes all such risks; (c) potential liability of EXAR Corporation is adequately protected under the circumstances.

Copyright 1996 EXAR Corporation

Application Note June 1997

Reproduction, in part or whole, without the prior written consent of EXAR Corporation is prohibited.