

Masstab	101.39%	Alexander C. Frank	Blatt : Raspberry PI
Änderung	23.12.2024 14:46	ETH QUANTUMOPTICS	
Ausgabe	24.12.2024 17:10		
Datei	DAC-ADC-HAT-10-2.T3001		

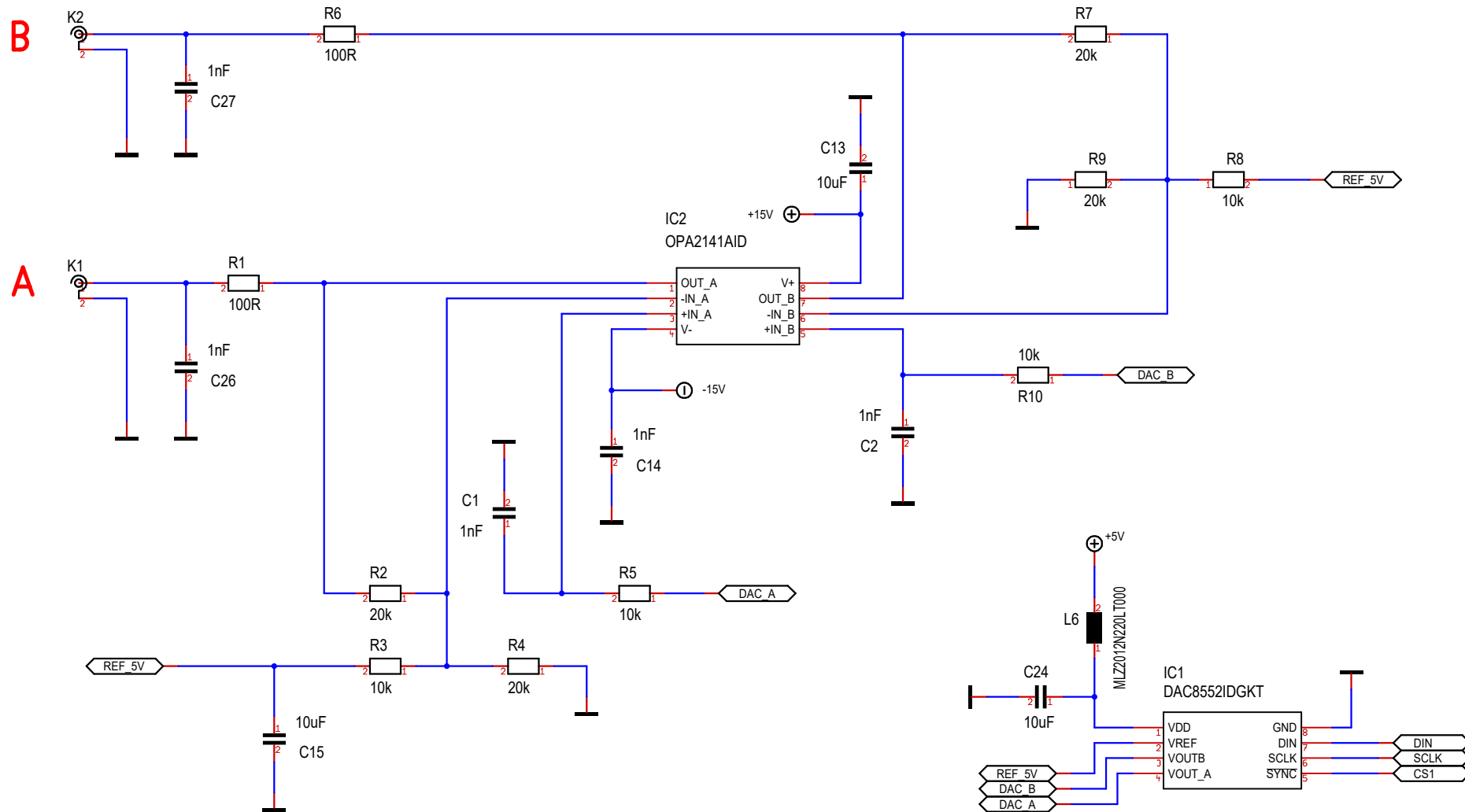

REF: <https://www.changpuak.ch/electronics/UnipolarVoltageOutputDAC-to-BipolarVoltage.php>

Masstab	101.39%	Alexander C. Frank	Blatt : DAC8552
Änderung	23.12.2024 14:46		ETH QUANTUMOPTICS
Ausgabe	24.12.2024 17:10		
Datei	DAC-ADC-HAT-10-2.T3001		

AIN0

AIN1

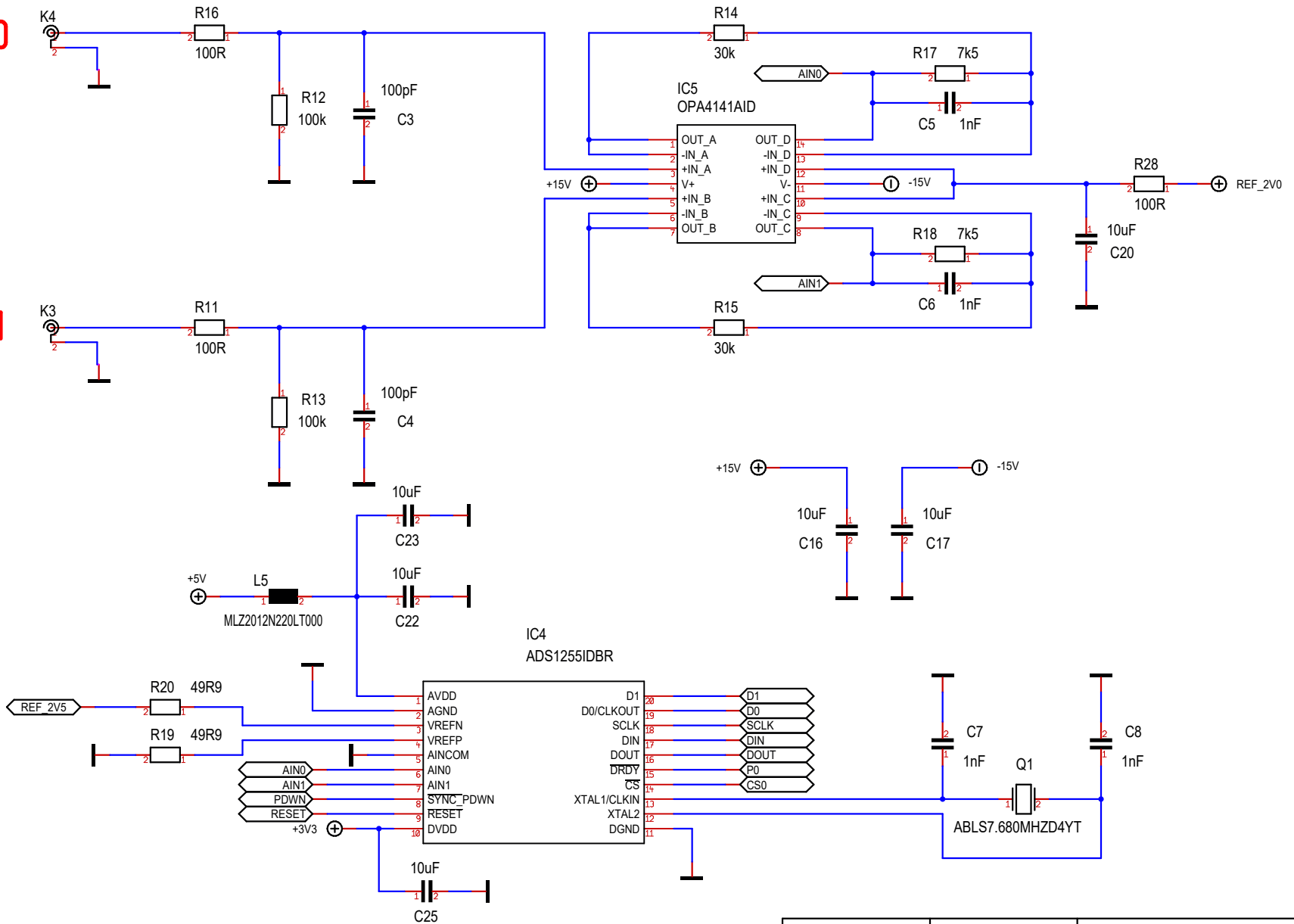

Masstab	101.39%	Alexander C. Frank	Blatt : ADS1255
Änderung	23.12.2024 14:46	ETH QUANTUMOPTICS	
Ausgabe	24.12.2024 17:10		
Datei	DAC-ADC-HAT-10-2.T3001		

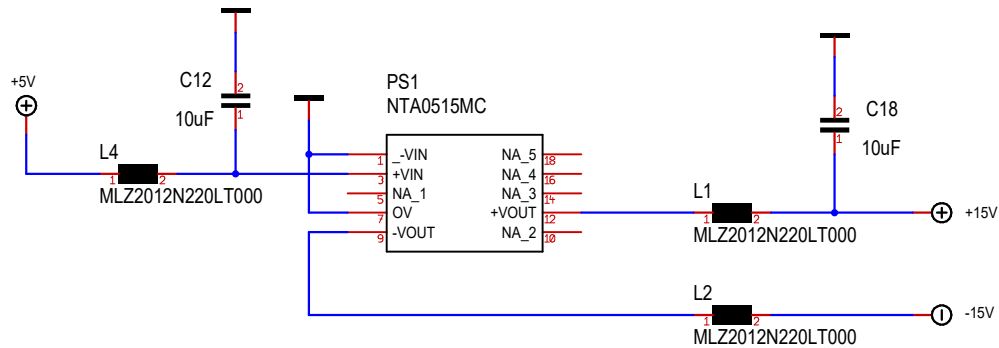
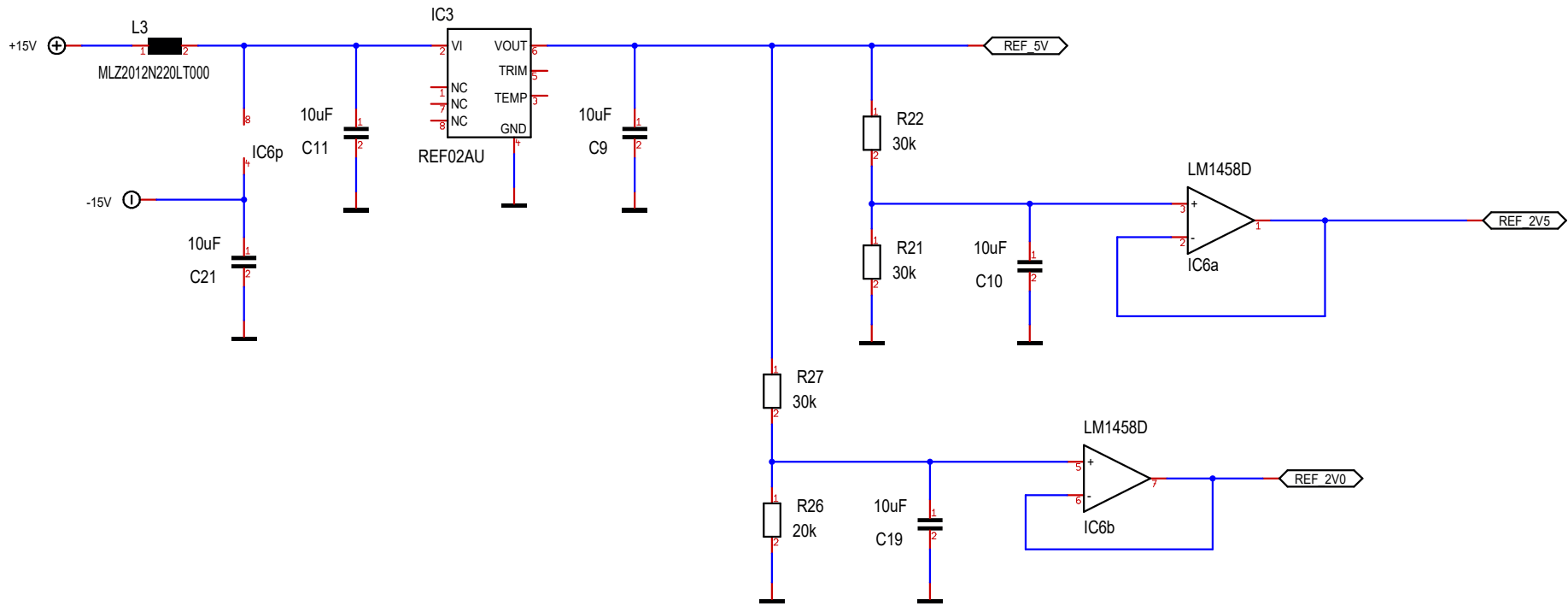

Masstab	101.39%	Alexander C. Frank	Blatt : Power Supply
Änderung	23.12.2024 14:46	ETH QUANTUMOPTICS	
Ausgabe	24.12.2024 17:10		
Datei	DAC-ADC-HAT-10-2.T3001		