

Massstab	101.39%	Alexander C. Frank	Blatt :MODULE_FREQ
Änderung	23.08.2022	18:34	<b>ETH</b> QUANTUMOPTICS
Ausgabe	24.08.2022	13:07	
Datei	Boots_ASM_5009-FREQ-4.T3001		

32 Bit → 4'294'967'296

All clocks are positive edge triggered.  
All other inputs are active low.

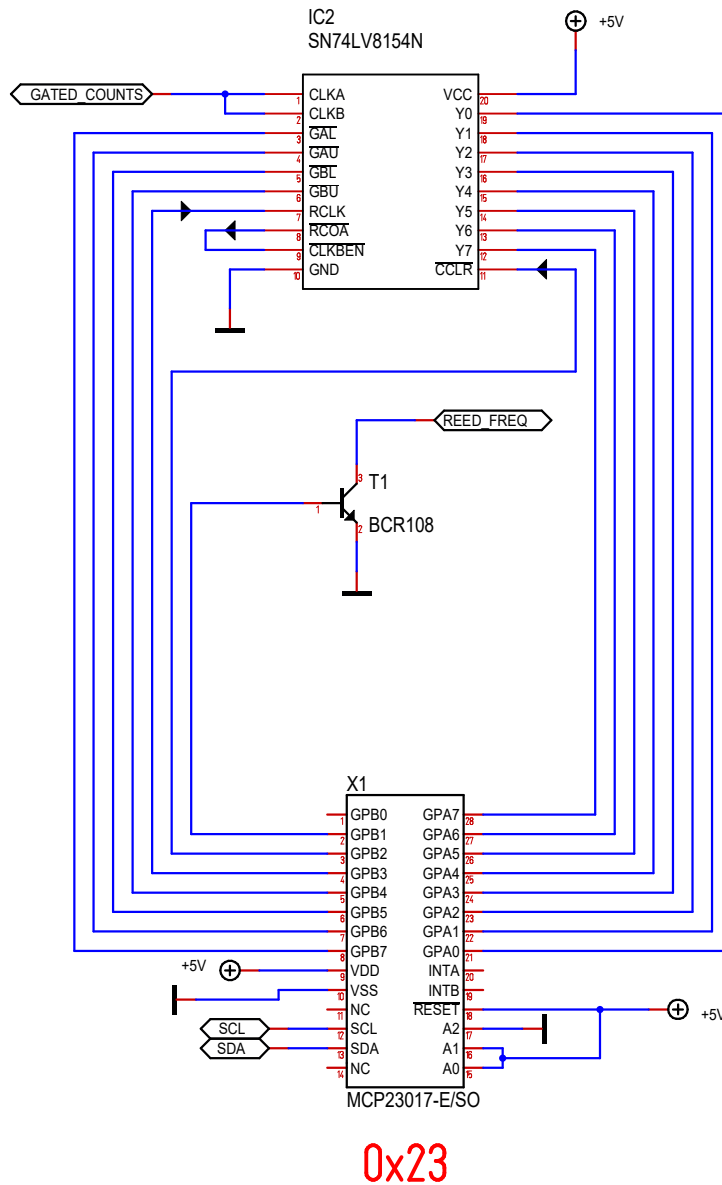

Chip Address	Hardwired Address			i <sup>2</sup> c Address
	A2	A1	A0	
000	GND	GND	GND	0x20
001	GND	GND	3V3	0x21
010	GND	3V3	GND	0x22
011	GND	3V3	3V3	0x23
100	3V3	GND	GND	0x24
101	3V3	GND	3V3	0x25
110	3V3	3V3	GND	0x26
111	3V3	3V3	3V3	0x27